

LIMPIAFONDOS AUTOMÁTICOS 2012



Certikin

Typhoon Top SURF



**Typhoon
SurfTOP**



**Typhoon
JuniorTOP**



**Typhoon
SmartTOP**



**Typhoon
CompassTOP**



**Typhoon
PlusTOP**

Certikin



Typhoon Top SURF



- Motores sin escobillas
 - Mayor eficiencia
 - Mayor tiempo de vida

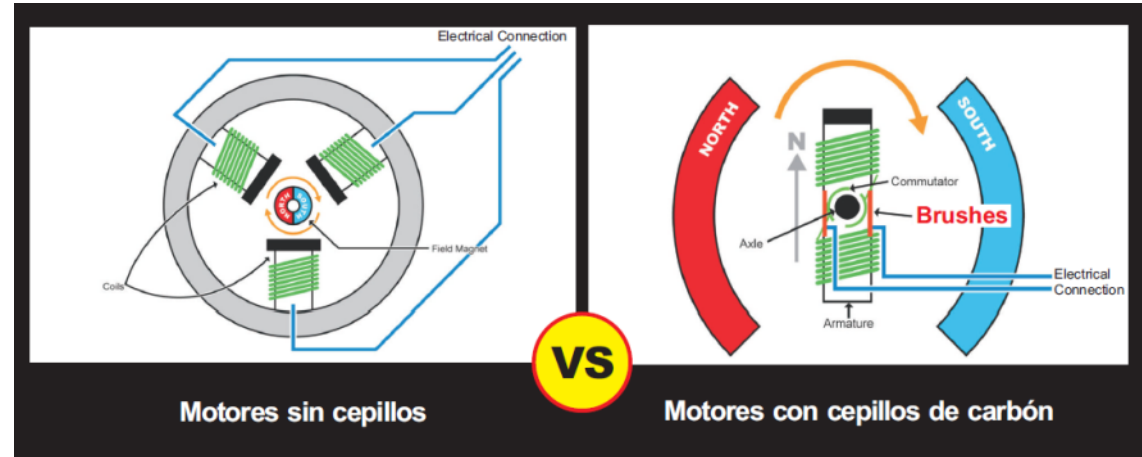

- Motor bomba refrigerada con aceite
 - Mayor tiempo de vida

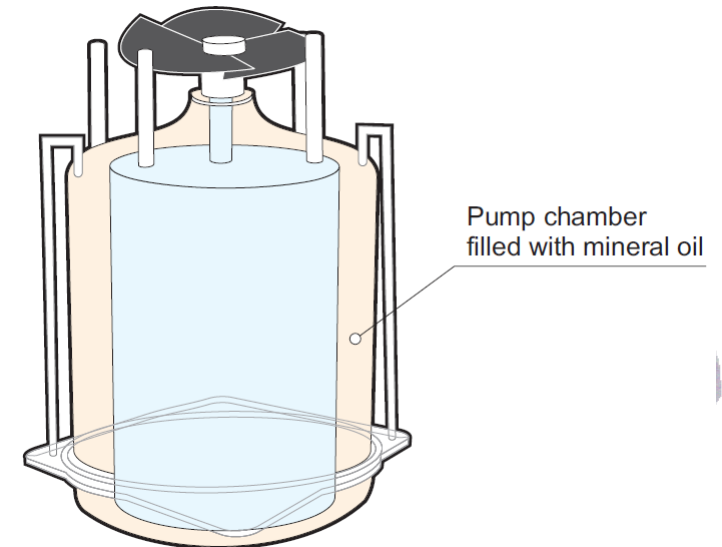

Certikin

Typhoon Top SURF



- Posibilidad de utilizar temporizador externo:
 - Permite dejar el robot en el agua y que inicie automáticamente el último programa de limpieza seleccionado cuando se activa.
 - Recomendado para usuarios que no pueden cuidar del robot durante unos días y desean mantener la piscina limpia.



Certikin



Typhoon Top SURF



- Acceso al filtro mediante pulsando un botón.

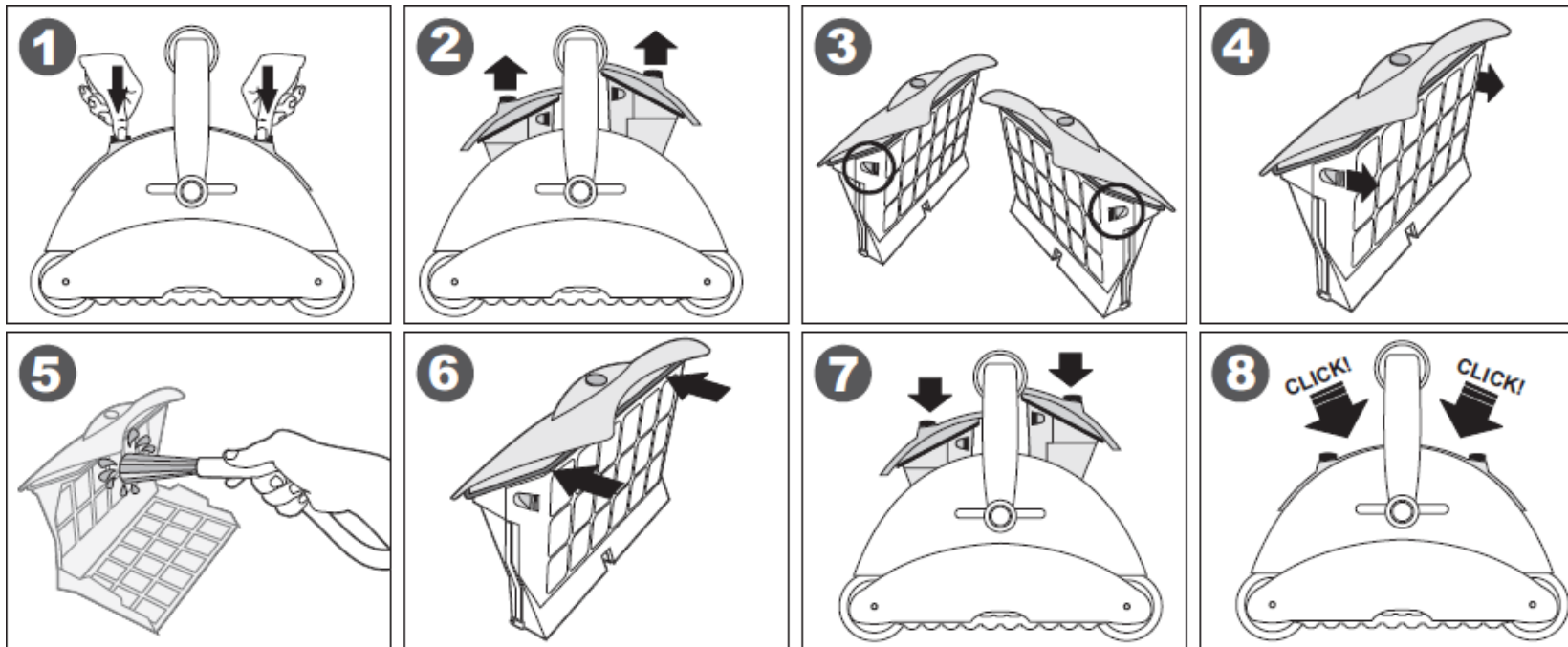

Certikin

Typhoon Top SURF



- Ajuste de la altura de las bocas de aspiración:
 - Permite ajustar la potencia de succión en cualquier circunstancia

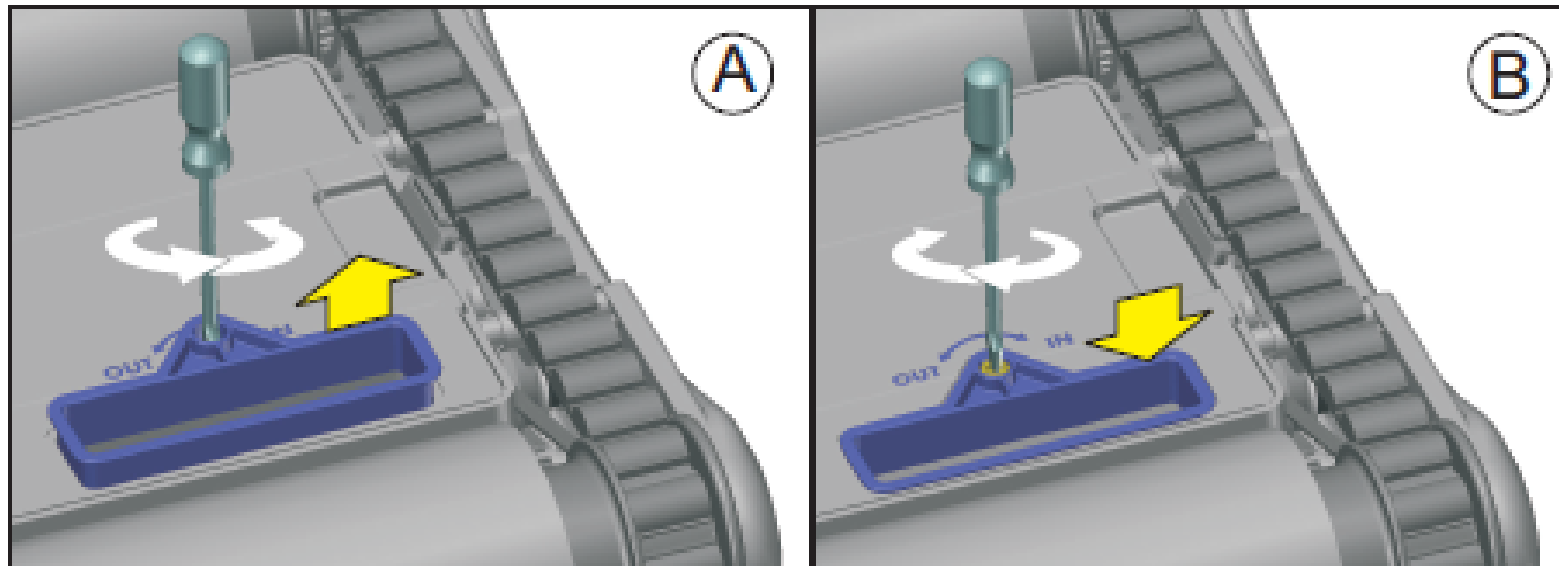

Certikin

Typhoon Top SURF



- Puede funcionar conectado a un temporizador externo

Certikin



Typhoon Top SURF



	Surf	Surf Top
Floor	yes	yes
Wall	no	no
RC	no	no
Pool area (m2)	60	60
Cycle time (h)	2,5	2,5
Aquasmart	no	no
External timer capability	no	yes
Check filter bag indication	no	no
Floating cable length (m)	17	18
Buggy/Caddy	no	no
Filtrated flow (m3/h)	17	17
Filter	reusable bag	push-pull top access case
Drive motor	24V DC brushless	24V DC brushless
Pump motor	24V DC brushless	24V DC brushless
Brushes	PVC	PVC
Power supply	Igloo	Basic SPS
Electrical specifications	230V / 50 Hz / 150 W	100-259 V/ 50-60 Hz / 150 W
Dimensions (cm)	<<	45*51*51
Weight (kg)	17	16
Warranty	2 years	2 years



Certikin

Typhoon Top JUNIOR



- Cepillos de PVA
 - Mayor adherencia en todas las superficies

Más tracción en piscinas de fibra de vidrio

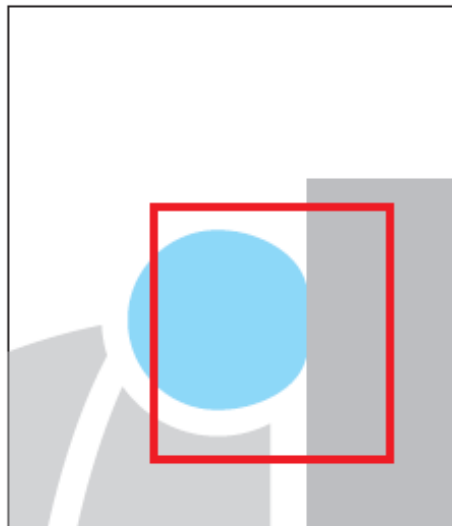

El pegamento entre los azulejos.

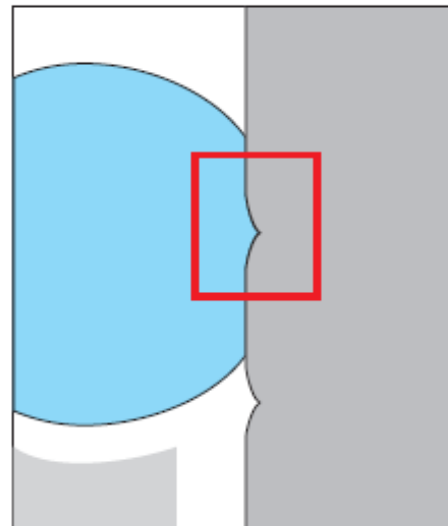

Certikin



Typhoon Top JUNIOR



- Modelo Buggy para transportar el robot

Certikin



Typhoon Top JUNIOR



	Junior	Junior Top
Floor	yes	yes
Wall	yes	yes
RC	no	no
Pool area (m2)	80	80
Cycle time (h)	3	3
Aquasmart	no	no
External timer capability	no	yes
Check filter bag indication	no	no
Floating cable length (m)	18	18
Buggy/Caddy	buggy	buggy
Filtrated flow (m3/h)	17	17
Filter	reusable bag	push-pull top access case
Drive motor	24V DC brushless	24V DC brushless
Pump motor	24V DC brushless	24V DC brushless
Brushes	PVA	PVA
Power supply	Transformer	Basic SPS
Electrical specifications	230V / 50 Hz / 150 W	100-259 V / 50-60 Hz / 150 W
Dimensions (cm)	45*51*51	45*51*51
Weight (kg)	22	18,2
Warranty	2 years	2 years



Certikin

Typhoon Top SMART



- Vibrating brush:
 - Cepillo oscilante para la limpieza de cualquier superficie
 - Puede cepillar la línea de flotación

Waterline

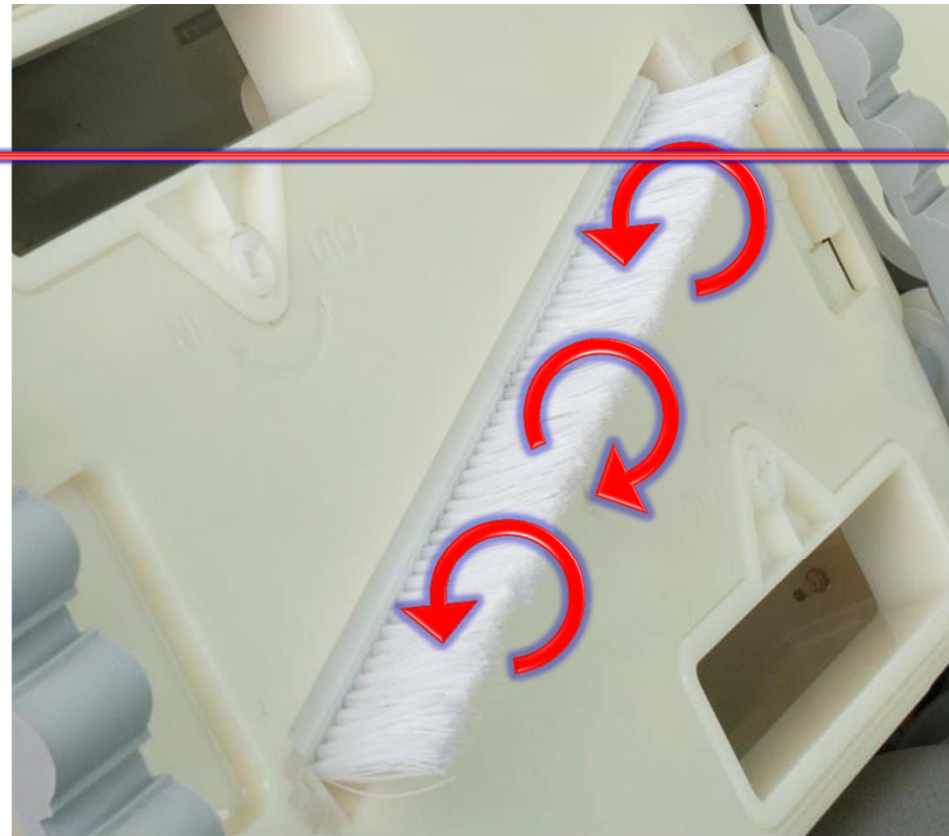

Certikin



Typhoon Top SMART



- LED indicador de filtro lleno:
 - Indica cuándo es necesario limpiar el filtro.



Certikin

Typhoon Top SMART



- Temporizador interno:
 - Excepcionalmente permite dejar el robot en el agua y que inicie automáticamente el último programa de limpieza seleccionado cada 2, 3 ó 4 días.



Certikin

Typhoon Top SMART



- Modelo Caddy para transportar el robot

Certikin



Typhoon Top SMART



Aquacontrol

	Cleaning program Mode nettoyage Programa de limpieza Reinigungsprogramm Programma di pulizia Programa de limpeza	PROGRAM 03	96h	
	Internal timer Minuterie interne Temporizador interno Interne Zeitschaltuhr Timer interno Temporizador interno	PROGRAM 02	72h	
	Check filter Vérifiez le filtre Revisé el filtro Filter überprüfen Controllare il sacchetto filtrante Verifique o Filtro	PROGRAM 01	48h	
	External timer Minuterie externe Temporizador externo Externe Zeitschaltuhr Timer esterno Temporizador externo			

- 3 programas:
 - Programa 01: 1 h limpieza “smart” (sólo suelo)
 - Program 02: 1.5 h limpieza “smart” (suelo y paredes)
 - Program 03: 2 h limpieza “smart” (suelo y paredes)
- LED indicador de limpieza de filtro
- Temporizador interno: puesta en marcha automática cada 2, 3 o 4 días.
- Puede funcionar conectado un temporizador externo

Certikin



Typhoon Top SMART



	Smart	Smart Top
Floor	yes	yes
Wall	yes	yes
RC	no	no
Pool area (m2)	80	80
Cycle time (h)	1.5 / 2	1 / 1.5 / 2
Aquasmart	yes	yes
External timer capability	yes	yes
Internal timer	no	yes
Check filter bag indication	no	yes
Electronic swivel	no	no
Mechanical cleaning	no	vibrating brush
Floating cable length (m)	18	18
Buggy/Caddy	caddy	caddy
Filtrated flow (m3/h)	17	17
Filter	reusable bag	push-pull top access case
Drive motor	24V DC brushless	24V DC brushless
Pump motor	24V DC brushless	24V DC brushless
Brushes	PVA	PVA
Power supply	Transformer	SPS 200
Electrical specifications	230V / 50 Hz / 150 W	100-259 V / 50-60 Hz / 150 W
Dimensions (cm)	45*51*51	45*51*51
Weight (kg)	21	18,2
Warranty	3 years	3 years



Certikin

Typhoon Top COMPASS



- Mando a distancia:
 - Permite dirigir el robot manualmente



Certikin



Typhoon Top COMPASS



- Swivel:
 - Sistema electrónico que compensa giros a derecha e izquierda de forma proactiva para que la relación sea 1:1



Certikin



Typhoon Top COMPASS

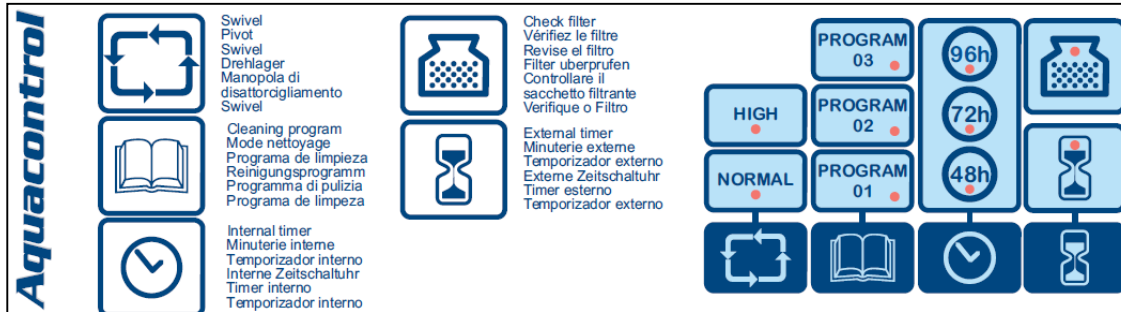

- 3 programas:
 - Programa 01: 1 h limpieza “smart” (sólo suelo)
 - Program 02: 1.5 h limpieza “smart” (suelo y paredes)
 - Program 03: 2 h limpieza “smart” (suelo y paredes)
- LED indicador de limpieza de filtro
- Temporizador interno: puesta en marcha automática cada 2, 3 o 4 días.
- Anti-nudos electrónico – On/Off
- Mando a distancia
- Puede funcionar conectado un temporizador externo

Certikin



Typhoon Top COMPASS



	Compass	Compass Top
Floor	yes	yes
Wall	yes	yes
RC	yes	yes
Pool area (m2)	80	80
Cycle time (h)	1.5 / 2	1 / 1.5 / 2
Aquasmart	yes	yes
External timer capability	yes	yes
Pool size adjustment	yes	no
Pool shape adjustment	no	no
Wall climbing frequency	yes	no
Internal timer	no	yes
Check filter bag indication	yes	yes
Electronic swivel	no	yes
Mechanical cleaning	no	vibrating brush
Obstacles detection	no	no
Floating cable length (m)	18	18
Buggy/Caddy	caddy	caddy
Filtrated flow (m3/h)	17	17
Filter	reusable bag	push-pull top access case
Drive motor	24V DC brushless	24V DC brushless
Pump motor	24V DC brushless	24V DC brushless
Brushes	PVA	PVA
Power supply	Transformer	SPS 300
Electrical specifications	45*51*51	45*51*51
Weight (kg)	22	20,9
Warranty	3 years	3 years



Certikin

Typhoon Top PLUS



- Ajuste a forma de piscina:
 - Permite al usuario seleccionar la forma de su piscina para que la electrónica determine el ciclo de limpieza más eficiente.

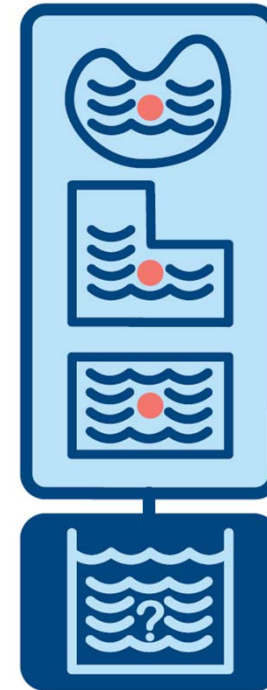

Certikin

Typhoon Top PLUS



- Active jets:
 - Sistema de agua a presión para levantar la suciedad de suelo y paredes.



Certikin

Typhoon Top PLUS



- Detección de obstáculos:
 - ON: el robot cambiará de dirección cada vez que encuentre un obstáculo
 - OFF: hay que activar esta opción si el robot cambia de dirección sin encontrar ningún obstáculo

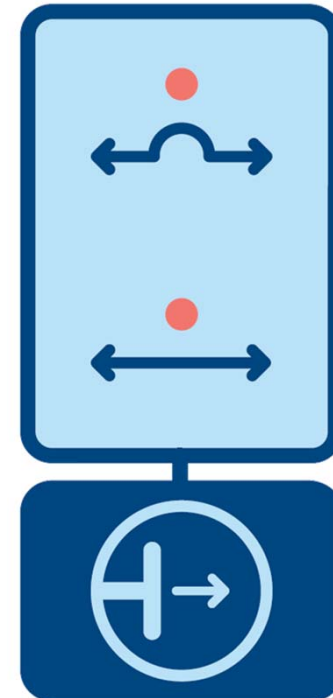

Certikin

Typhoon Top PLUS



- 3 programas:
 - Programa 01: 1.5 h limpieza “smart” (sólo suelo)
 - Programa 02: 2 h limpieza “smart” (suelo y paredes)
 - Program 03: 2.5 h limpieza “smart” (suelo y paredes extendidos)
- LED indicador de limpieza de filtro
- Temporizador interno: puesta en marcha automática cada 2, 3 o 4 días.
- Swivel electrónico – On/Off
- Mando a distancia
- Ajuste a forma piscina
- Detection de obstáculos – On/Off
- Puede funcionar conectado un temporizador externo

Certikin



Typhoon Top PLUS



	Plus	Plus Top
Floor	yes	yes
Wall	yes	yes
RC	yes	yes
Pool area (m2)	100	100
Cycle time (h)	1 / 2 / 3	1.5 / 2 / 2.5
Aquasmart	yes	yes
External timer capability	no	yes
Pool size adjustment	yes	yes
Pool shape adjustment	yes	yes
Wall climbing frequency	yes	yes
Internal timer	no	yes
Check filter bag indication	yes	yes
Electronic swivel	no	yes
Mechanical cleaning	no	active jets
Obstacles detection	yes	yes
Floating cable length (m)	23	23
Buggy/Caddy	caddy	caddy
Filtrated flow (m3/h)	17	17
Filter	reusable bag	push-pull top access case
Drive motor	24V DC brushless	24V DC brushless
Pump motor	24V DC brushless	24V DC brushless
Brushes	PVA	PVA
Power supply	Viva	SPS 400
Electrical specifications	230V / 50 Hz / 150 W	100-259 V / 50-60 Hz / 150 W
Dimensions (cm)	45*51*51	45*51*51
Weight (kg)	23,5	20
Warranty	3 years	3 years



Argumentos de venta generales



Filtro

- **Typhoon Top:** de fácil limpieza y 80 μ
- **Typhoon:** mucho menor micraje y mayor superficie filtrante



Motor

- En **TODA** la gama
 - Motores sin escobillas
 - Motores con baño de aceite para mejorar la refrigeración

Garantía

- Modelo sólo suelo: dos años
- Modelos suelo/paredes: 3 años (exc. Junior)

Sistema extra de limpieza

- Cepillo oscilante: Typhoon Top SMART y Typhoon Top COMPASS
- Active jets: Typhoon Top PLUS

Electrónica

- Transformadores digitales capaces de recordar el último programa y con una gran variedad de funciones para elegir.

Certikin

